

# ENERGY PLUS COMMERCIAL WASHER



Coin slide and coin box not included.

## CAE2763BQ—27" Energy Plus Commercial Washer

- Washer Accepts the Following Compatible Payment Systems (not included):
  - Coin Slide
  - Coin-Drop
  - Card Reader
  - Non-Coin Payment Configurations
- 2.9-Cu.-Ft. Wash Basket
- Energy Plus, Low Water Factor
- 3 Wash Cycles: Permanent Press, Normal, Delicates
- Cycle Indicator LEDs
- High-Speed Spin—700 RPM (maximum)
- 1/3 HP Motor
- Porcelain Top and Lid, Rustproof Stainless Steel Torx® Control Panel Security Screws
- Galvanized, Painted Heavy-Gauge Cabinet Back, Side and Front Panels, Removable Front Service Panel
- **3-Year Limited Parts Only Warranty\***
- Money Acceptors Sold Separately

\*Call 800-662-3587 for warranty details.

**2013 Department of Energy Compliant  
Modified Energy Factor: 1.85**

**Water Factor: 6.85**

**On average, uses 20 gallons per cycle—the  
lowest water consumption for Whirlpool®  
Commercial top-load washers.**

### FOR YOUR CUSTOMERS

- Large Capacity Wash Basket is Ideal for Family-Size Loads
- Proven Cleaning Performance
- Extra-Large Lid and Tub Opening
- 3 Cycle Options: Permanent Press, Normal and Delicates for a Wide Range of Fabrics
- Separate Temperature Control
- Ergonomic Control Knobs

### BELT DRIVE SYSTEM

- 27" Heavy-Duty Commercial Washer Features the Reliable Belt-Drive for Reduced Downtime and Increased Profits
- Front and Bottom Serviceable

### AUTOMATIC LOAD SENSING

Adjusts water fill level based on load size, reducing water usage by up to 18 gallons per wash cycle.

### BALANCE RING ADAPTER—CLOTHES GUARD

Discourages overloading and helps keep small items out of the pump.



### INDUSTRIAL STRENGTH WATER INLET HOSES

- Tested to 1100 PSI
- Extra-Long 6' Hoses

# ENERGY PLUS COMMERCIAL WASHER



## Whirlpool® Energy Plus Commercial Washer

WASHER SPECIFICATIONS	
<b>MODEL</b>	CAE2763BQ
<b>GENERAL INFORMATION</b>	
Accepts the following payment systems: Coin Slide, Coin-Drop, Card Reader and Non-Coin Payment Configurations. Modern design and look with all metal console and ergonomic control knobs. Automatic lid lock feature. Commercial-grade, color-coded water inlet hoses with brass couplings and rubber drain hose included.	Electronic Temperature Control Large Capacity 2.9-Cu.-Ft. Basket
<b>BASKET VOLUME</b>	2.9 Cu. Ft.
<b>MOTOR</b>	
120 Volt 1/3 HP, 1/4 kw with thermal overload protection	Single-speed, permanent split capacitor, reversible motor.
Spin RPM—Maximum	700
<b>MAXIMUM RATED CURRENT—AMPS (VOLT)</b>	8 (120)
<b>ELECTRICAL REQUIREMENTS</b>	
Breaker/Fuse—AMPS	15
<b>SHIPPING WEIGHT (EST.)</b>	152 lbs. Crated, 136 lbs. Uncrated
<b>DIMENSIONS</b>	
Cabinet Width—in. (mm)	27 (686)
Cabinet Depth—in. (mm)	25.9 (658)
Cabinet Height—in. (mm) at Metercase Top	43 (1092)

Energy information is available online at [www.whirlpoolcommerciallaundry.com](http://www.whirlpoolcommerciallaundry.com)

NEW YORK CITY  
M.E.A.



Dimensions are for planning purposes only. For complete information, see installation instructions packed with product.

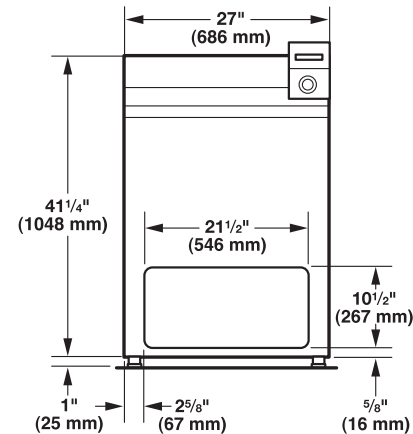

WASHER FRONT VIEW

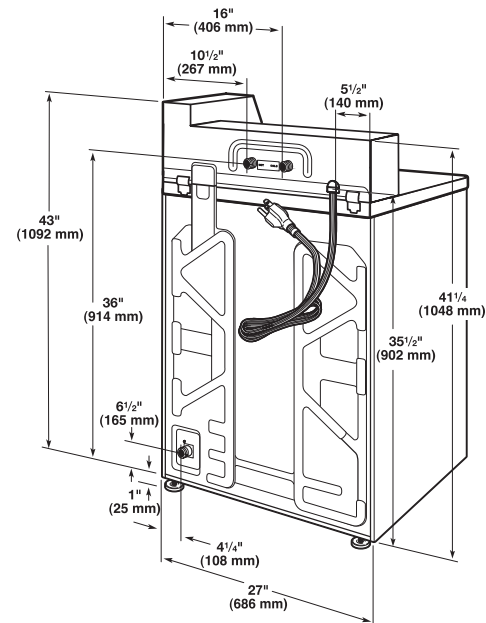

WASHER BACK VIEW



## 3-YEAR LIMITED PARTS ONLY WARRANTY

For a period of time from the date of original purchase through the time listed above, the designated parts that fail in normal commercial use will be repaired or replaced free of charge for the part itself, with the owner paying all other costs, including labor, transportation and customs duty. Chemical damage is excluded from all warranty coverage. See complete warranty for details.

To Locate a Distributor Near You, Please Visit [www.whirlpoolcommerciallaundry.com/distributor](http://www.whirlpoolcommerciallaundry.com/distributor), or call 1-800-662-3587.